

S.NO	CATALOG NUMBER	L	N
1	NACC750-2B	2.63 [67]	2
2	NACC750-3B	4 [102]	3
3	NACC750-4B	5.38 [171]	4
4	NACC750-5B	6.75 [171]	5
5	NACC750-6B	8.13 [207]	6
6	NACC750-8B	10.88 [276]	8

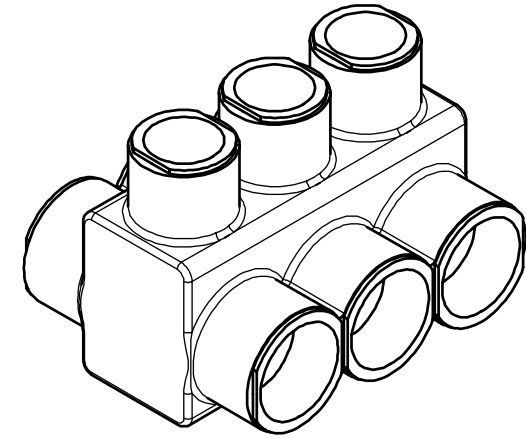

SCREWS ARE SUPPLIED WITH CONNECTOR AND COMES FULLY ASSEMBLED.

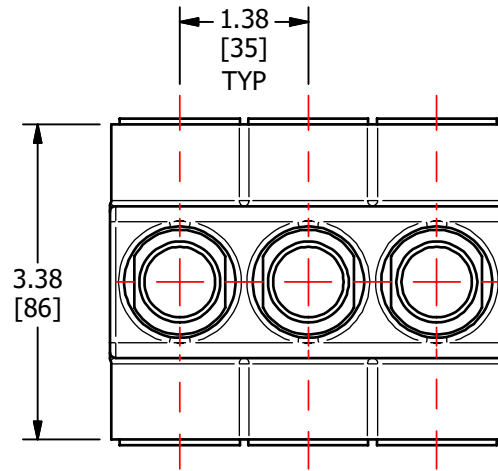
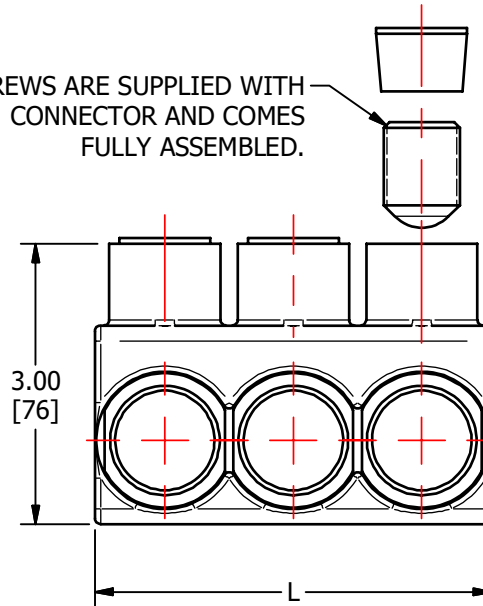

- CONNECTOR FABRICATED FROM ALUMINIUM ALLOY FOR CONDUCTIVITY AND STRENGTH.
- CONNECTOR IS ENCAPSULATED IN CLEAR PVC RATED AT 240 VOLTS PER MIL.
- CLEAR COVER ALLOWS VISUAL INSPECTION OF CONDUCTORS DURING INSTALLATION.
- FULLY TESTED TO ANSI C119.4 FOR CLASS 'A' CONNECTORS
- DUAL-RATED CONNECTORS - FOR ALUMINUM OR COPPER CONDUCTORS
- CLEAR INSULATED SECONDARY CONNECTOR
- CONDUCTOR RANGE: 750 KCMIL - #2 AWG

					TO ORDER CMC PRODUCTS	DRAWN BY: TS	NAME OF PART:	CAT. NO.:
					UNITED STATES 1-513-860-4455	08-26-20	ENCAP. BAR ASSEMBLY	SEE TABLE
					CANADA 1-800-361-6975	CHECKED BY:	DWG NO:	A
					MEXICO 011-52-722-265-4400		C17598110-S (CHARTED)	
A	NEW DRAWING CREATED		08-26-20	TS	FOR PRODUCT INFO www.cmlugs.com	DRAWING NOT TO SCALE		SHEET NO: 1 OF 1
REV.	DESCRIPTION	ECN	DATE	INIT.				

THIS INFORMATION IS PROPRIETARY TO CONNECTOR MFG. CO. AND IS NOT TO BE DISCLOSED OUTSIDE OF CONNECTOR MFG. CO. WITHOUT A CONFIDENTIALITY AGREEMENT



CONNECTOR MANUFACTURING CO.

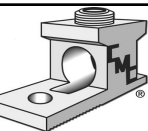

HAMILTON, OHIO